

# Customer Information Sheet

DRAWING No.: M50-390XX42

SHEET 2 OF 2

IF IN DOUBT - ASK

©

NOT TO SCALE

THIRD ANGLE PROJECTION

ALL DIMENSIONS IN mm

**NOTES:**

1. ALL TOLERANCES ARE  $\pm 0.25$  UNLESS OTHERWISE STATED.
2. RECOMMENDED HOLE SIZE =  $\varnothing 0.65 \pm 0.05$ mm.

**SPECIFICATION:**

**MATERIAL:**  
 MOULDING = NYLON 6T, UL94V-0, BLACK  
 CONTACT = PHOSPHOR BRONZE  
**FINISH (CONTACT):**  
 42 = 0.15 - 0.08 $\mu$  GOLD ON CONTACT AREA,  
 2.5 - 3.0 $\mu$  100% TIN ON TAILS,  
 ALL OVER 0.7 - 1.3 $\mu$  NICKEL

**ELECTRICAL:**  
 CURRENT RATING (ALL CONTACTS ARE ELECTRICALLY LOADED) = 1A MAX  
 CONTACT RESISTANCE = 30 m $\Omega$  MAX  
 INSULATION RESISTANCE = 5,000 M $\Omega$  MIN  
 DIELECTRIC STRENGTH = 600V AC/DC

**MECHANICAL:**  
 PIN RETENTION = 4.4N MIN  
 SOLDERABILITY = 250°C FOR 3 TO 5 SECONDS  
 DURABILITY = 600 OPERATIONS

**ENVIRONMENTAL:**  
 TEMPERATURE RANGE = -40°C TO +105°C

**PACKING:**  
 TUBE  
 FOR COMPLETE SPECIFICATION, SEE COMPONENT SPECIFICATION  
 C029XX (LATEST ISSUE)

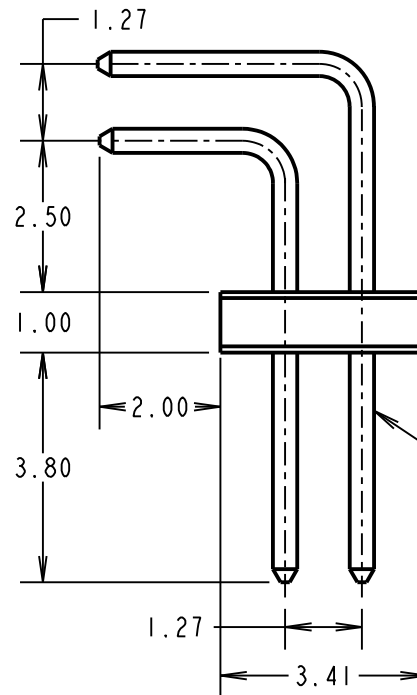
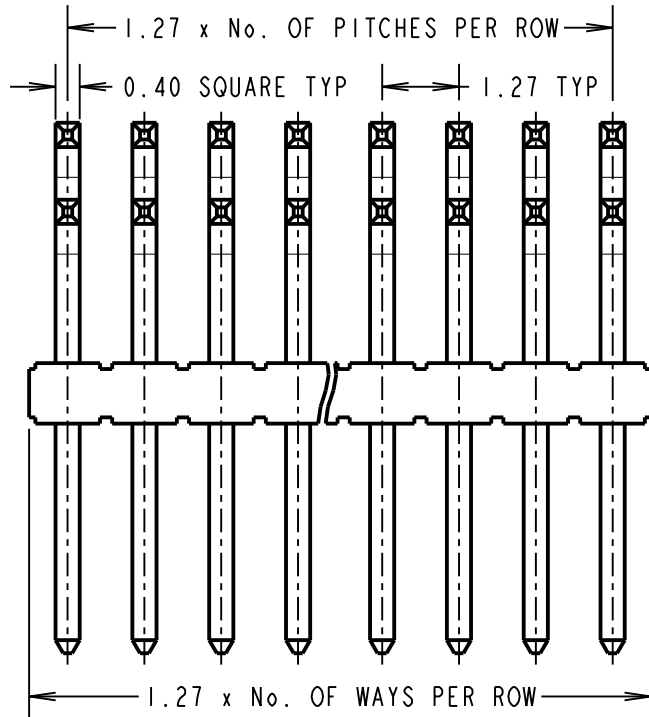

SELECTIVE GOLD  
 IN THIS AREA

ORDER CODE:

**M50-390XX42**

No. OF WAYS PER ROW ———  
 01 TO 50

FINISH: \_\_\_\_\_  
 42 = SELECTIVE GOLD + 100% TIN

RA	9	21.12.11	11604
NAME	ISS.	DATE	C/NOTE
APPROVED:		R. ADDE	
CHECKED:		M.G. PLESTED	
DRAWN:		J. KIER	
CUSTOMER REF.:			
ASSEMBLY DRG:			

**HARWIN**

www.harwin.com  
 technical@harwin.com

THIS DRAWING AND ANY INFORMATION OR DESCRIPTIVE MATTER SET OUT HEREON ARE CONFIDENTIAL AND COPYRIGHT PROPERTY OF THE HARWIN GROUP AND MUST NOT BE DISCLOSED, LOANED, COPIED OR USED FOR MANUFACTURING, TENDERING OR FOR ANY OTHER PURPOSE WITHOUT THEIR WRITTEN PERMISSION.

**TOLERANCES**  
~~X =  $\pm 1$ mm  
 X.X =  $\pm 0.25$ mm  
 X.XX =  $\pm 0.10$ mm  
 X.XXX =  $\pm 0.01$ mm  
 ANGLES =  $\pm 5^\circ$   
 UNLESS STATED~~

**MATERIAL:**

SEE ABOVE

**FINISH:**

SEE ABOVE

**S/AREA:**

mm<sup>2</sup>

**TITLE:**

1.27mm PITCH DIL  
 HORIZONTAL PIN HEADER

**DRAWING NUMBER:**

**M50-390XX42**

SHT  
 2 OF 2